

Institutional issues and political challenges in scaling up agroforestry: The case of Landcare in the Philippines

Delia C. Catacutan, PhD. & Edith Tejada
World Agroforestry Centre
ICRAF Research Site, Lantapan, Bukidnon 8722
Email: delia_icraf@yahoo.com

Abstract

Agroforestry has considerable potential to address the twin problems of rural poverty and environmental degradation in the Philippine uplands. The World Agroforestry Centre (ICRAF) has been promoting agroforestry by working with a range of partners including local governments and communities. In particular, ICRAF helped initiate the Landcare Program, a successful farmer-led extension program based on community landcare groups, in the Municipality of Claveria in the northern Mindanao. The Landcare Program has resulted in widespread adoption of agroforestry practices and, as a consequence, has been scaled up to several other sites to achieve wider adoption, and increase the impacts of agroforestry. Results of four case studies to assess the factors promoting effective scaling up of agroforestry within the Landcare Program are presented. It was found that Landcare was associated with rapid adoption of soil conservation and agroforestry technologies in the different sites, due to the strong latent demand for the technologies. Landcare groups were the key to success but required on-going support to function well. Reliance on local governments as the 'lead institution' tied the Landcare program to political and budgetary cycles, undermining sustainability. The case studies indicate that scaling up agroforestry practices depends on the viability of the landcare approach. It was also found that some features of the local context, the effectiveness of implementing strategies, the relevance of the landcare approach, and institutional capacity promoted successful scaling up. Furthermore, institutional and political barriers to scaling up should be removed, and broader institutional and political support should be in place to promote rapid scaling up of agroforestry.

Introduction

The issue of scaling up has recently gained attention based on the pragmatic argument that successful technical innovations should be scaled up to a level that will generate larger economic and environmental benefits more rapidly (Catacutan & Cramb 2004). However, scaling up is a multifaceted subject, embedded in socio-political and institutional contexts, hence different users of the concept consider different issues (Catacutan & Cramb 2004). In a review of scaling up agroforestry innovations, Franzel et al. (2001) conclude that scaling up entails not only quality planting materials of different tree species, but building institutional capacities in the community to sustain the innovation and adoption process of agroforestry practices. This paper presents the results of a PhD research that examines the scaling up of agroforestry practices in the southern Philippines through the Landcare Program. Specifically, the study aimed to examine the requirements for effective scaling up of agroforestry technologies in the Philippines. The study was conducted in four municipalities in Mindanao, all of which were research and development sites of the World Agroforestry Centre (ICRAF).

Background of Landcare Program in the Philippines

The World Agroforestry Centre with partners, SEAMEO Regional Centre Graduate Study and Research in Agriculture (SEARCA) and Catholic Relief Service (CRS) implement the Landcare Program, with funding from the Australian Centre for International Agricultural Research (ACIAR), Agencia Expanola de Cooperacion Internacional (AECI), and the Australian Agency for International Development (AusAid). Landcare is a farmer-centred program involving farmer-to-farmer knowledge sharing, training, and capacity building. As conceived by ICRAF, the Landcare Program involved technical and institutional innovations, described as the "landcare approach", with three cornerstones, namely, appropriate technologies, institution building, and

partnerships. Technical innovations were based on natural vegetative strips (NVS) and branching pathways for agroforestry development typically starting with nursery establishment. NVS is a variant of the SALT system, established by leaving the native weeds to re-vegetate in the unplanted strips along the contour line, eventually forming stable natural barriers to erosion (Garrity & Mercado 1994; Sabio 2002; Stark 2000). The three-way partnership of farmers, local government units (LGU), and technical facilitators (in this case, ICRAF) was described as the landcare triangle, and was considered an institutional innovation. Another institutional innovation was the formation of landcare groups and associations. As an approach, Landcare centres on the formation of community Landcare groups and municipal-wide Landcare associations, supported to varying degrees through partnerships with government and non-government agencies. Such groups identify problems at the local level and mobilise information, community effort, and finances to help improve the management of their soil, water, vegetation, and other natural resources. Activities included training, cross-farm visits, slide shows, formation of landcare groups, and farmer extension of conservation technologies, among others. Facilitating these activities was a major component of the Landcare Program. Volunteerism, participation, and self-help initiatives were important values of the Landcare Program.

Landcare emerged in the mid-1990s in the municipality of Claveria, where the World Agroforestry Centre – had established a research base and was working with farmers to develop and test suitable conservation practices. Landcare was then viewed as an approach that could rapidly and inexpensively disseminate agroforestry technologies, based on an effective partnership between stakeholders. In Claveria, the initial success of the Landcare approach was impressive with an unprecedented increase in adoption of conservation and agroforestry technologies. This raised the possibility of scaling up to other Philippines sites. With additional funding from ACIAR and AECI, Landcare was scaled up in the southern and central Philippines (in 1999), with currently more than 10,000 farmers and about 30 partner institutions involved. However, this was not achieved without issues and challenges; the factors for successful scaling up were found to be more complex than those associated with technology dissemination and adoption. Unless the elements for successful scaling up are in place, the wider promotion of agroforestry will not be feasible.

Methodology

This paper reports on some key findings of a PhD research conducted by the author from 2002 to 2004. Four case studies were undertaken namely, the municipality of Claveria in Misamis Oriental Province and the municipalities of Lantapan, Malitbog, and Manolo Fortich in Bukidnon Province. These sites encompassed the essential features of the Philippine uplands, including rapid population growth, the expansion of settlement and intensive agriculture into ecologically fragile areas, land degradation, and poverty. The sites were selected because they had all experienced a Landcare program but with progressively reduced technical and institutional input from ICRAF and differential support from local government (Table 1). The case studies relied on the following sources of data: (1) key informant interviews with farmers, project staff, local officials, and other key partners; (2) focus group discussions with landcare groups; (3) project databases; (4) local government statistics; and (5) participant observation.

Table 1. Resources used in the Landcare sites

Sites	ICRAF's Input	Local Government Input
Claveria	Fully staffed (ICRAF's first research site)	Medium to high level of financial and human resources
Lantapan	Reduced number of staff (ICRAF's second research site)	Low level of financial and human resources
Malitbog	1 full time facilitator	Medium level of financial and human resources
Manolo Fortich	1 half-time facilitator	Low level of financial and human resources

Results and Discussions

The findings and conclusions of the study are summarized in the following sections of this paper namely:

Modes of scaling up

The pathways, strategies, nature of activities, and varying levels of technical and institutional input constituted the different modes of scaling up at each site (Table 2). Municipal governments were the most common pathway for scaling up. With decentralised governments, LGUs have a legitimate stake in natural resource management (NRM) and sufficient autonomy to act on their decisions, hence their support was actively sought. Integration of Landcare within their existing programs (e.g., NRM plans, agricultural extension program) was a common strategy of the three modes of scaling up. Uvin et al. (1994) say that integration is desired by an increasing number of non-government organisations (NGOs) because it offers the fastest possibility for significant scaling up. However, this required the LGU to adopt the principles of the Landcare Program (e.g. participatory, farmer-driven) and, at the same time, ICRAF needed to adjust to the LGUs' administrative and political systems, sometimes even to a politician's personal whims. For instance, in Manolo Fortich the structure of Landcare from the sitio to the municipal level as developed in Claveria was modified because the mayor pursued the idea of training barangay facilitators, which was insufficient in terms of generating support at various levels (sitio, barangay, and municipal levels). Clearly, the interaction and relationship of the key actors was crucial, sometimes resulting in painful compromises and tradeoffs.

Table 2. Components of ICRAF's modes of scaling up Landcare in the study sites

Mode	Site	Year Started	Pathway	Strategy	Type of Activities	ICRAF Support	LGU Support
1	Lantapan	1997*	Local Development Planning	Integration in the Municipal NRM Plan	Direct impact activities	Full staff support but less than Claveria	Low level financial and human resources
2	Malitbog	1998	Agricultural Extension	Integration in the Agricultural Extension Program	Combination of direct and indirect impact activities	1 full time Landcare facilitator	Low to medium level financial support; High level human resources
3	Manolo Fortich	2000	Local Development Planning	Integration in the Municipal Comprehensive Plan	Indirect impact activities	1 part time Landcare facilitator	Low level human resources

*Landcare was introduced to the LGU in 1997, but on-ground activities started in 1999.

The three main types of scaling up activities were: (1) direct impact activities, where an ICRAF staff member was engaged to work directly with farmers, with implicit goals of influencing the institutional partners; (2) a combination of direct and indirect impact activities where an ICRAF staff member worked with farmers and the LGU to demonstrate and train the technicians to facilitate Landcare; and (3) indirect impact activities such as conducting training sessions and hosting farm visits to influence the partners to implement their own activities. In one sense, the Claveria case followed the first type when it scaled up Landcare within the municipality. The Lantapan site also followed the first type, while Malitbog used the second type, and Manolo Fortich used more of the third type.

According to Uvin & Miller (1996), indirect impact activities enable scaling up without necessarily expanding the organisational base of the supporting institution and is a common approach among NGOs. However, they add that there is a great potential for synergy between direct and indirect impact activities. In ICRAF's case, working directly with farmers and the LGU helped to build its track record, and made it more confident to enter into indirect impact activities with partners in other sites. Figure 1 illustrates the three types of scaling up activities in the study sites.

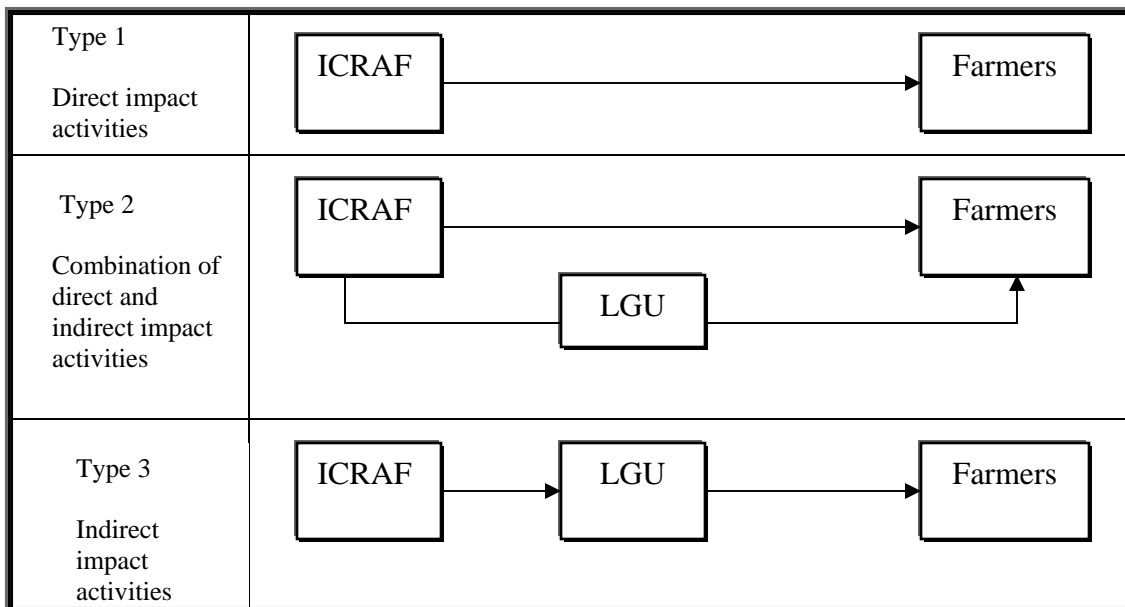

Figure 1. Types of scaling up activities

Landcare outcomes in the study sites

- *Rate and Extent of Technology Adoption*

The rate of technology adoption was unprecedented in the study sites. On average, 60 per cent of initial NVS adopters had moved on to include agroforestry, which involved planting timber and fruit trees and perennial crops such as banana or coffee along the NVS, on farm boundaries, and in small woodlots within a farm unit. Because of the growing interest in agroforestry, the number of trees planted by farmers in the four sites had reached 472,000 by the middle of 2003, with Claveria the highest, followed by Lantapan and Malitbog, and Manolo Fortich the lowest (Figure 2). The survival rate of planted trees, however, had not been accounted.

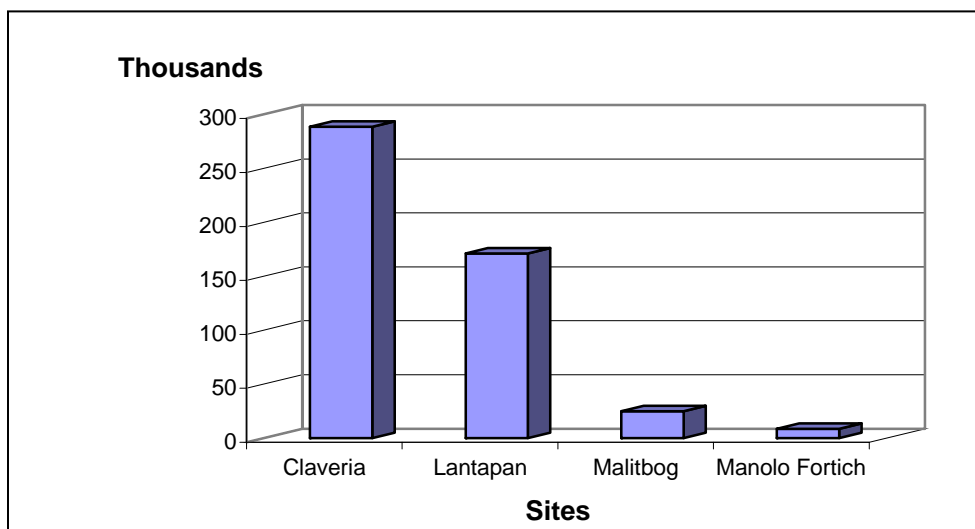

Figure 2. Number of trees planted by farmers in the study sites, 1996-mid 2003

During the Landcare Program (from 1996 to 2003), the total number of farmers who had adopted NVS and agroforestry (or conservation technologies) in the four sites was nearly 3,000 with Claveria the highest, followed by Lantapan and Malitbog, and Manolo Fortich the lowest (Figure 3). The total area on which these technologies were applied was 3,448 hectares (Table 3).

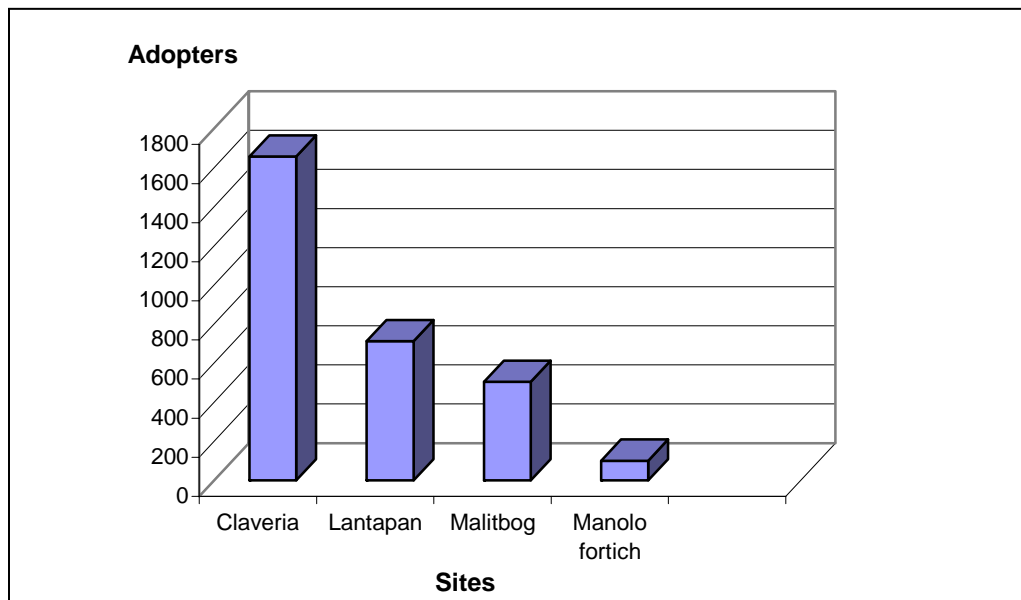

Figure 3. Number of farmer-adopters of agroforestry and NVS in the study sites

Table 3 shows the extent of adoption in relative terms, enabling a better comparison between sites. The percentage of total cropped area applied with conservation technologies was 11 per cent in Lantapan and Claveria and 8 per cent in Malitbog, but negligible in Manolo Fortich. Thus, where Landcare was successfully scaled up, the area and extent of adoption was quite similar despite large differences in the total cropped area. The proportion of actual adopters to potential adopters was much higher in Claveria (27 per cent) than in Lantapan (13 per cent) or Malitbog (15 per cent). However, it should be considered that the number of potential adopters in Lantapan may have been much lower than indicated in Table 3, since the number of farming households had decreased due to employment in agribusiness firms. The average rate of adoption was also higher in Claveria (236 per year) than in Lantapan (178) or Malitbog (100).

Table 3. Rate and extent of technology adoption in the study sites, 1996-2003

Sites	Period (years)	Total cropped area* (ha)	Total cropped area applied with conservation technologies (ha)	Per cent of cropped area	Total number of farming households**	Total number of adopters	Adopters as per cent of farming households	Average number of adopters per year
Claveria	7	16,543	1,820	11	6,233	1,656	27	236
Lantapan	4	10,797	1,229	11	5,550	712	13	178
Malitbog	5	4,983	390	8	3,274	504	15	100
Manolo Fortich	1	14,566	9***	.06	3,872	100	3	-
Total			3,448			2,972		

*Upper limit of potential area on which conservation technologies could be applied

**Upper limit of potential adopters

***Assuming that 9,000 trees were planted on farms with a density of 1000 trees/hectares.

The longer-term impact of the adopted technologies makes it difficult to accurately reflect larger trends of environmental and or economic benefits. However, farmers' perceived benefits of the adopted technologies were significant. Some cases of farm improvements have been documented by ICRAF. Considering that some farmers continued to adopt NVS, and had applied more complex agroforestry systems, i.e., livestock integration, bee-keeping, and tree-farming, and were involved in wider conservation efforts, such as water quality monitoring, riparian stabilisation, and tree planting in public places (e.g. streets, playgrounds), environmental and economic benefits would be expected. The benefits of these efforts had not yet been systematically documented but were likely to be important. This however, needs more attention to provide an estimate of the benefits of conservation technologies, although a World Bank (1989) study of conservation practices in the Philippines found that the productivity and environmental benefits of increased adoption of conservation technologies are potentially substantial even in the absence of quantitative estimates.

Except for Manolo Fortich, technology adoption in the study sites followed an S-shaped adoption curve with an increasing rate in the first two years and a declining rate in subsequent years. The early phase was associated with training, cross-farm visits, and group formation, suggesting the influence of these activities on technology adoption. The declining phase may have reflected the reduction in these activities or simply reflected a ceiling to adoption. Nonetheless, the following years saw a diversification of activities that farmers were engaged in, a type of functional scaling up in Uvin & Miller's (1996) taxonomy of scaling up. Some farmers had moved on to other productivity-enhancing and community-wide conservation efforts. In Claveria and Lantapan, some farmers were involved in timber and fruit tree seedling production and marketing, while others were involved in training and research and community projects (e.g., riparian stabilization, water quality monitoring). Hence, to some extent, the decline in the rate of technology adoption was offset by other activities.

The lower rate of adoption in the scaling up sites coincided with the decreasing level of ICRAF's technical and institutional support. However, it would be overly simplistic to conclude that there was a causal effect between the degree of external input (technical and institutional) and technology adoption, without considering the time element, the number of potential adopters and the potential areas for conservation at each site (as discussed earlier), and the socio-economic and political factors unique to each site. For instance, while the potential reason for the short-term existence of Landcare in Manolo Fortich was ICRAF's limited input, the inconsistency of LGU support and the low level of human and social capital of farmers were also limiting factors. Also, it was important to consider the adoption ceiling at each site as suggested by the S-shaped adoption curve. In some cases, the adoption ceiling might be high but low in the others. In the case of Lantapan, despite the strong presence of ICRAF, the adoption ceiling was approached quickly due to rapidly rising off-farm employment.

Nevertheless, it could be argued that the rate and extent of technology adoption in the study sites had been significant with the Landcare Program. Hence, the Landcare Program was "better" than the status quo.

- *Impacts on Institution Building*

In Claveria, the contribution of the Claveria Landcare Association (CLCA) to the success of Landcare was indisputable. The CLCA helped in recruiting members and promoting adoption, and represented a voice in policy decision-making and resource allocation. The CLCA was influential in the passage of local policies that supported the activities of Landcare.

The Lantapan Landcare Association (LLCA) developed into a strong and enterprising organisation despite limited LGU support. It is likely that the complacent attitude of the LGU towards Landcare had pushed the LLCA to become a more resourceful and self-reliant organisation. For instance, with facilitator motivation, a Landcare office and training centre was established using solicited funds from the LLCA members and from friends and supporters. It

was also able to network with tree growers in Mindanao for the marketing of tree seeds and seedlings through its affiliated group, the Agroforestry Tree Seed Association of Lantapan (ATSAL). The Malitbog Landcare Association (MLCA) continued supporting and coordinating group activities in the barangays, though its own activities were rather limited. Technicians, barangay officials, and the Landcare facilitator helped to support the activities of the MLCA. On the other hand, the sudden decline of the Landcare Program in Manolo Fortich due to a hostile political situation immobilised the Manolo Fortich Landcare Association (MFLCA).

Such organizations as the CLCA, LLCA, and MLCA have played critical roles in the development of the Landcare Program. For Cramb (2004), they helped to build social capital encouraging bonding within the landcare groups and bridging them to a wider network of supporters and service providers. They took on the characteristics of secondary level organization which, according to Hinchcliff et al. (1999) and Scherr et al. (2001), can help to manage common property resources, regulate private resource management to protect community interests, organise community investments to improve natural resource conditions, share knowledge, cooperate to market products or environmental services, or advocate for community interests with policymakers and other influential external actors. Uphoff (1994) adds that such local institutions are more likely to be successful in natural resource management if they belong to an identifiable group or community with its own authority and structure.

The strong institutional support provided by ICRAF and the LGU helped to promote the process of institution building in Claveria and Malitbog. Conversely, the low-level of institutional support from ICRAF and from the LGU inhibited this process in Manolo Fortich, while ICRAF took on much of the task of institution building in Lantapan. The message here was that local organisations under the right circumstances could be effective institutions for resource management, but even if local groups were strong, other actors, particularly LGUs and committed external agencies (e.g. ICRAF) were needed to help mobilise local groups.

- *Impacts on Partnership Building*

Partnership was central to the Landcare Program. In Claveria, it was evident that the partnership between ICRAF, the LGU, and the farmers flourished over time. The notion that success was dependent on this three-way partnership of actors was based on the Claveria experience, and subsequently became a key hypothesis for testing in the scaling up sites. Apart from the LGU, the CLCA had successfully established partnerships with other community sectors and outside stakeholders, including national-level NGOs and international organisations (e.g., Philippine-German Fund).

Political transition and factionalism were common denominators in Lantapan and Manolo Fortich. Efforts to establish a partnership with the LGU in Lantapan were generally hampered by on-going political factionalism, hence ICRAF's efforts were directed to building partnerships with local groups, and NGOs and project staff. Similarly, in Manolo Fortich, LGU partnership did not succeed when the political leadership changed a year after Landcare had started. Political transition and administrative changes generally aborted the Landcare Program. However, between the two sites, Landcare thrived more in Lantapan because ICRAF had a longer-term presence and more focused institutional and technical input than in Manolo Fortich. This indicates that in the absence of strong LGU support, a more focused partnership from an external agency is necessary to offset the weakness of the LGU. Meanwhile, there was evidence of effective LGU partnership in Malitbog manifested through the support provided for training, technical, and livelihood projects. However, horizontal or vertical linkages between landcare groups and other agencies were weak due to the limited number of project interventions; hence partnership was limited to the LGU.

Pretty & Ward (2001) point out that while institutional maturity is likely to be related to the availability of social capital locally, appropriate inputs from government and voluntary agencies

are needed. This implies the need for on-going investment to enrich the existing human and social capital of the actors involved in the Landcare Program.

- *Related Impacts*

In connection with efforts to scale up Landcare from 1996 to 2003, ICRAF had established partnerships or linkages with at least 30 local, national, and international organisations, including funding agencies. The Claveria and Lantapan sites were serving as learning nodes, hosting a significant number of farmers, government officials, technicians, development practitioners, and researchers who had approached ICRAF to learn about Landcare. Farmers had been providing training and site visits for outside clients. The study of Sabio (2002) revealed that social capital is embedded in the landcare approach and transformative learning has taken place between and among the actors involved. However, the value of these outputs is hard to measure. Some benefits have also been accrued from investment by the LGUs into Landcare activities, especially training and nurseries.

Factors promoting success in scaling up Landcare

At the personal level, farmers identified several factors that encouraged participation in Landcare, but the promoted technologies were the dominant factor. At the group level, several factors contributed to success, but cooperation and unity, effective communication and leadership, and the members' knowledge of promoted technologies (human capital) were common across groups, and across the study sites. At the community level, the LGU and ICRAF support, effective coordination and partnership, the promoted technologies, and the training and facilitation provided were identified as important factors for success.

These factors were all embodied in the landcare approach, described by the three cornerstones, namely, promotion of appropriate technologies (*NVS* and *agroforestry*), institution building, and partnerships. Hence, the landcare approach was integral to the success of the Landcare Program, without which it could easily disintegrate. Manolo Fortich was a good example, where the limited input from ICRAF, the inconsistent LGU support, and the weakness of the landcare groups undermined the landcare approach and inhibited the development of the Landcare Program. In the case of Lantapan, the limited LGU support was offset by ICRAF's strong presence and effective partnership with the LLCA, sustaining the Landcare Program despite the challenges it faced. The implication is that the degree of partnership, or the strength of the landcare triangle varies from one site to another depending on the resources available to, and the circumstances of the actors involved, affecting the viability of the landcare approach. In other words, the success of the Landcare Program was related to the viability of the landcare approach. However, while the cornerstones of the landcare approach were integral to success of the Landcare Program, particular features of the local context enhanced or limited success. For purposes of this study, the ***local context*** is viewed as the sum of the ***socio-economic, institutional, and political*** features of the study sites (1). As Biggs (1990) emphasised, technology generation and promotional activities take place in a historically defined political, economic, agroclimatic, and institutional context. The influence of these contextual factors is crucial in determining the outcomes of a particular project (Cramb 2000b). In addition, success was promoted by ***effective implementation strategies*** (2), the ***relevance of Landcare to the actors involved*** (3), and the ***institutional capacity of the sponsoring agency that is ICRAF's catalytic role in the Landcare Program*** (4). In this case, it can be concluded that the promotion and scaling up of agroforestry practices was made possible, and apparently, successful because of the viability of the landcare approach, within which, agroforestry was embedded.

Key institutional and political challenges in scaling up

Drawing upon the Landcare experience, we identify the key institutional and political challenges within local and national contexts impinging upon successful scaling up of agroforestry practices, either as a single technology intervention or incorporated in a complete dissemination program such as Landcare.

- *Institutional capacity of local government units (LGUs)*

LGUs were generally found to have low or modest investment in agricultural development compared to that in physical infrastructure and social welfare services. This problem had several origins. First, local politicians usually gave priority to activities with short-term tangible outcomes (i.e., roads, bridges) to secure votes for the next election. Second, LGUs were dependent on aid from the Department of Agriculture (DA) and from politicians for agricultural projects. Third, this could be partly attributed to flaws in the Local Government Code. The devolution of functions for agricultural extension and NRM to LGUs was not matched with the funding needed to perform the devolved functions. LGUs were swamped with salaried personnel who had to be paid locally, soaking up local funding. Even so, the ratio of technicians to farming population was low. Hence, lack of staff and funding to implement extension activities was a common complaint among technicians. Furthermore, promotion of conservation technologies was often ignored by many LGUs due to the priority given by the national government to production technologies that were inconsiderate of conservation goals. Hence, while the institutional arrangements were in place at the local level, the issue was one of institutional capacity in terms of the number of available technicians, their expertise, and funding. In other words, the human and social capital of the technicians to enable them to work effectively with farmers was an important consideration in scaling up.

- *Local political dynamics*

It is widely recognized that LGUs play an important role in local development. This role presupposes effective democratic structures for local self-administration. However, the delivery of local government functions has a strong political dimension; in fact, the decisions for planning and implementation of programs are largely influenced by political considerations in the form of the patron-client politics.

In Claveria, the LGU's contribution was crucial for success. The connection of local influentials with politicians paved the way for instituting LGU support. The shift in political leadership was held almost exclusively in the hands of a strong political family, providing for a stable political environment. Similarly, the LGU of Malitbog played a critical role, substituting for the physical presence of ICRAF. Just as in Claveria, the political transition was held entirely in the hands of one political family. Hence, both sites had a stable political environment that was supportive of the Landcare Program. In contrast, Landcare received marginal local government support in Lantapan and Manolo Fortich because of political instability. In both sites, political transition, factionalism and administrative issues affected the Landcare Program. Clearly, the landcare triangle, referring to the three-way partnership of key actors, was strong in Claveria and Malitbog, and weak in Lantapan and Manolo Fortich. However, as mentioned earlier, despite the weakness of the landcare triangle in Lantapan, Landcare succeeded because of ICRAF's strong presence, offsetting the weakness of the LGU. In Manolo Fortich, administrative changes created a vacuum for Landcare, eventually dissipating farmers' interest and, with ICRAF's limited presence, the partnership collapsed.

The case studies revealed just how the dynamics of local politics had positively or adversely affected program implementation. The power and control of political families has been criticised as detrimental to the exercise of democracy. According to Baguiro (2004), this limits the choice of the voters and the pace of democratization because public office is treated like a family heirloom, handed down to the next family generation. However, the cases of Claveria and Malitbog showed that political families engendered political stability, which promoted the sustainability of the Landcare Program. Although political stability is not only achieved with political families, this case demonstrated that locally initiated programs could be more sustainable where political families provided political stability.

In contrast, the cases of Lantapan and Manolo Fortich demonstrated how political rivalry resulted in political and administrative factionalism, and created implementation problems. It is reported in the literature that the Philippine administrative system is constantly subjected to

modifications when a new political leader comes to office distrusting the old administration. According to Varela (1996), this distrust, often bordering on hostility, creates political instability and tension, which in turn affects the continuity and stability of public service. Hence, scaling up Landcare will be challenging in politically sensitive areas, where the level of political commitment and support that made Landcare successful in the original site is absent. Ultimately, politics can either be a positive or a negative factor; the political dimension of agroforestry promotion and scaling up is thus an important consideration.

- *Inadequate national level institutional and political support for agroforestry and NRM*

It is widely agreed that the policy environment of a country affects agriculture and extension in many ways. Government investment in public extension and structural adjustment programs are dependent on national policies, and so are organizations for technology development (Bebbington & Farrington 1993; Kaimowitz 1993; Pretty 1998; Scherr et al. 2001; Swanson 2003). Efforts to forge a relationship between local initiatives and higher level government are classified by Uvin & Miller (1994; 1996) as political scaling up. This is recognized as a potentially powerful strategy for scaling up grassroots initiatives. However, the NGO informants in this study were concerned about the sustainability of the Landcare Program if the national government takes on the role of sponsoring agency or even to coordinate the process of scaling out to different regions. Government programs are often coterminous with the terms of politicians and government administrators. Political dynamics and administrative changes affect the stability and continuity of public service. In deciding to work closely with government, any project places itself at some risk from the political cycle (Coxhead & Buenavista 2001). Hence, Schorr et al. (1999) argue that scaling up will remain the exception rather than the rule unless rigid bureaucracies and negative political influences that undermine the attributes of program success are changed. This raises the need for an enabling environment to remove the barriers to scaling up.

Historically, the Philippines started to implement large-scale projects in community forestry, irrigation, and watershed management in the 1970s. The 1990s were a period of increased support from government and international funding agencies for rehabilitation efforts, which emphasized people-oriented and community-based approaches. Many project-driven policy initiatives were implemented through NGAs with support from bilateral and multilateral aid agencies. However, there were mixed results from these large investments, with some promising cases and many unsustainable or failed projects. Project failure was attributed to a myriad of factors including ineffective policy enforcement, inherent weakness of extension programs in the different agencies, insufficient training of extension officers, and poor communication. The apprehensions expressed by the majority of NGO informants regarding the possibility of scaling up Landcare through the national government were thus well founded. Despite this, they recognized the important role of the national government to expedite a scaling up process, and to provide a broader framework for supporting localized NRM.

In brief, there is a need for an enabling environment in the form of broad-level policy support to promote the scaling up of agroforestry and grassroots NRM initiatives. A process of political scaling up is thus important. It is recognized that, in the Philippines, achieving the elements of an enabling environment is extremely difficult in the short term. However, it is worth outlining what those elements might be.

First, effective policies with complementary programs for localized NRM efforts are most needed. Policies should have complementary measures to work well. However, a closer look at existing environmental policies showed a clash of specific provisions, and lack of a complementarity between programs. For instance, NRM functions have been devolved to LGUs, but there is no clear guideline for disbursing environmental expenditures, limiting the LGU's capacity to fund environmental projects. This is a clear manifestation of an incomplete devolution, rendering the policy vague and ineffective. Varela (1996) also found conflicting laws with ambiguity in policy intent and content. The interpretation of policies complicates the

situation; even if policies are clear, the interpretation of these policies is often biased toward what is culturally acceptable or personally beneficial, covering up the true intent and content of the policy (Varela 1996). Hence, an essential step to create an enabling policy environment would be to untangle the ambiguity of the intent and content of existing environmental policies and to formulate effective policy instruments (e.g., tenure and other support programs) that stimulate investments for sustainable agriculture and NRM.

Second, and in connection with the above, a focused strategy to mainstream the goals of sustainable agriculture and NRM in broad development goals should be emphasized in the policy agenda. Much has been said about sustainable agriculture and NRM, but governments at various levels have paid lip service to these, as seen in the obvious contradiction between policy and practice. For example, Coxhead & Buenavista (2001) found that efforts to influence forest, land, and water use in a sustainable direction are undermined by agricultural policies that raise prices received by farmers for crops that are erosive and very demanding of inorganic fertilizers. One practical strategy would be to mainstream NRM activities in LGU extension programs, just as gender and development concerns are now mainstreamed in government activities.

Third, capability building for agricultural extension personnel and concerned government officials at all levels is important. The limited technical expertise and facilitation skills of technicians and the poor internalization of NRM goals among public officials undermine the potential of local NRM initiatives, and these were recurrent issues in the case studies. Continued capability building improves technical skills, develops positive attitudes, provides motivation, and develops commitment among public officials and government personnel. Sosmena (1996) says that capability building in all aspects of governance and development is primordial in improving public service.

Finally, a more difficult and ambitious element would be systemic change within the bureaucracy. Such change should include shifts in the values and attitudes of politicians, government administrators, and personnel towards promotion of agroforestry, sustainable agriculture technologies, and effective NRM. However, this will not come easily under a culture of bureaucratic mediocrity. In the absence of a major shift in political culture, attitudinal change may only be expected from rare dedicated government officials and personnel. According to Varela (1996) the culture of mediocrity revolves around a mixed system of merit and competence required by civil service law and the tradition of political patronage. Funding limitations have aggravated this, as the government is unable to meet the basic and higher needs of personnel, leaving them with very little desire for professionalism. Hence, the idea of positive change, although recognized or desired by public officials and personnel would remain unattainable unless systemic change is instituted within the entire bureaucracy.

Conclusion

The apparent success of agroforestry promotion in the Landcare Program in northern Mindanao raises the potential for further scaling up, but the architecture for a broader scaling up process is still in flux. There were apprehensions about national government leading the process due to the mixed results of previous projects and the administrative behavior of the bureaucracy. Local environmental governance engendered by the devolution process has provided the Landcare Program with great opportunities and challenges, but the issue that remains is removing the institutional and political barriers to scaling up, and establishing a broader enabling environment that promotes rapid scaling up of agroforestry practices.

References

Baguioro, L 2004, *Political dynasties still thriving in the Philippines*, Straits Times Interactive, <http://straitstimes.asia1.com.sg>, viewed 19/05/2004.

- Bebbington, A & Farrington, J 1993, 'Governments, NGOs and agricultural development: perspectives on changing inter-organisational relationships', *Journal of Development Studies*, vol. 29, no. 2, pp. 199-219.
- Appold, SJ & Phong, D 2001, 'Patron-client relationship in a restructuring economy: an exploration of interorganisational linkages in Vietnam', *Economic Development and Cultural Change*, vol. 50, no. 30, p. 47.
- Arcenas, A 2002, 'Farmer-led soil conservation initiative in a developing country setting: The case of the Claveria Landcare Association in Claveria, Misamis Oriental, Philippines', PhD Dissertation thesis, Michigan State University.
- Asian Development Bank 1999, *A Study of NGOs in Asia*, <http://www.adb.org>, viewed 30/09/2004.
- Baguioro, L 2004, *Political dynasties still thriving in the Philippines*, Straits Times Interactive, <http://straitstimes.asia1.com.sg>, viewed 19/05/2004.
- Batario, R 1998, *This Hydra Called Corruption: The Philippine Experience*, <http://www.lga.org.ph>, viewed 12/1/2003.
- Bebbington, A & Farrington, J 1993, 'Governments, NGOs and agricultural development: perspectives on changing inter-organisational relationships', *Journal of Development Studies*, vol. 29, no. 2, pp. 199-219.
- Bebbington, A 1997, 'New States, New NGOs? Crises and Transitions among Rural Development NGOs in the Andean Region', *World Development*, vol. 25, no. 11, pp. 1755-65.
- Berman, P & Nelson, B 1997, 'Replication: Adapt or Fail', in A Altshuler & R Behn (eds), *Innovations in American Government*, Brookings Institute Press, Washington D.C., pp. 319-31.
- Bhatnagar, OP & Desai, GR 1987, 'Management of Agricultural Extension', *Journal of Rural Development in India*, pp. 1-66.
- Biggs, S 1990, 'A multiple source of innovation model of agricultural research and technology promotion.' *World Development*, vol. 18, no. 11, pp. 1481-99.
- Biggs, S & Smith, G 1995, 'Contending coalitions in agricultural research and development: Challenges for planning and management', paper presented to Evaluation for a New Century: A Global Perspective, Vancouver, Canada.
- Biggs, S & Neame, A 1995, 'Negotiating Room for Manoeuvre: Reflections Concerning NGO Autonomy and Accountability within the New Policy Agenda', in M Edwards & D Hulme (eds), *Non-Governmental Organisations-Performance and Accountability: Beyond the Magic Bullet*, Earthscan Publications Ltd., London, pp. 31-40.
- Biggs, S 1997, 'Rural Development: Livelihood, coping and influencing strategies of rural development personnel', in *Project Appraisal*, Beech Tree Publishing, Watford Close, Guildford, England, vol. 12, pp. 101-6.
- Catacutan, D & Mercado, A 2001a, 'The Triadic Approach: Some Experiences in Landcare Philippines.' in International Institute for Rural Reconstruction (ed.), *Enhancing Ownership and Sustainability: A Resource Book on Participation*, IFAD, ANGOC, IIRR, Philippines and India, p. 335.
- Catacutan, D.C. & Cramb, R.A. (2004). Scaling up adoption of contour-hedgerow farming in the southern Philippines: the landcare approach. Poster-Paper presented at the 4th International Crop Science Congress. Brisbane, Australia. September 2004.
- Catacutan, D.C. & Cramb, R.A. (2004). Mobilising Communities for Ecoagriculture: Lessons from Landcare in the Philippines and Australia. Paper presented at the 1st International Conference and Practitioner's Fair on Ecoagriculture. Nairobi, Kenya. September 2004.
- Cramb, RA 2000b, 'Process Influencing the Successful Adoption of New Technologies by Smallholders', in WW Stur, PM Horne, JB Hacker & PC Kerridge (eds), *Working with Farmers: The Key to Adoption of Forage Technologies*, Australian Centre for International Agricultural Research (ACIAR), Canberra, A.C.T, pp. 11-22.
- Cramb, RA 2000c, *Soil Conservation Technologies for Smallholder Farming Systems in the Philippines Uplands: a Socioeconomic Evaluation*, ACIAR monograph series ; No. 78., ACIAR, Canberra, ACT.

- Cramb, RA 2004, 'Social Capital and Soil Conservation: evidence from the Philippines', paper presented to 48th Annual Conference of the Australian Agricultural & Resource Economics Society, Melbourne, Australia.
- Cramb, RA & Culasero, Z 2003, 'Landcare and Livelihoods: The Promotion and Adoption of Conservation Farming Systems in the Philippine Uplands', *International Journal of Agricultural Sustainability*, vol. 1, no. 2, pp. 141-54.
- Franzel, S, Cooper, J & Denning, G 2001, 'Scaling Up the Benefits of Agroforestry Research: Lessons Learned and Research Challenges', *Journal for Development in Practice*, vol. 11, no. 4, pp. 524-34.
- Franzel, S, Cooper, J, Denning, G & Eade, D (eds) 2002, *Development and Agroforestry: Scaling Up the Impacts of Research*, Oxfam Association with ICRAF.
- Garrity, DP 2000, *The Farmer-Driven Landcare Movement: An Institutional Innovation with Implications for Extension and Research*, Southeast Asian Regional Research Programme. International Centre for Research in Agroforestry, Bogor, Indonesia.
- Gundel, S, Hancock, J & Anderson, S 2001, *Scaling-Up Strategies for Research in Natural Resource Management: A Comparative Review*, Natural Resource Institute, Chatham, UK.
- Pretty, J 1998, 'Supportive Policies and Practice for Scaling Up Sustainable Agriculture', in NG Roling & MAE Wagemakers (eds), *Facilitating Sustainable Agriculture*, Cambridge University Press.
- Pretty, J & Frank, BR 2000, 'Participation and Social Capital Formation in Natural Resource Management: Achievements and Lessons', paper presented to International Landcare Conference and Exhibition, Melbourne, Australia.
- Pretty, J & Ward, H 2001a, 'Social Capital and the Environment', *World Development*, vol. 29, no. 2, pp. 209-27.
- Pulhin, J & Dizon, JT 2003, 'Politics of the tenure reform in the Philippine forest land', paper presented to Politics of the Commons: Articulating Development and Strengthening Local Practices, Chiang Mai, Thailand.
- Sabio, EA 2002, 'Social Capital and Transformative Learning: Linkages and Dynamics in Inter-organisational Relations within the Landcare Approach in the Philippines', PhD Dissertation thesis, Cornell University.
- Scherr, S, Amorusangusin, J, Javier-Chiong, ME, Garrity, DP & Sunito, S 2001, 'Local Organizations in NRM in the uplands of Southeast Asia: Policy Context and Institutional Landscape', paper presented to Sustaining Upland Development in Southeast Asia: Issues, Tools and Institutions for Local Natural Resource Management, Makati, Philippines.
- Scherr, S 1999a, 'Soil Degradation, A threat to developing-country food security by 2020?' in *Discussion Paper No. 27, International Food Policy Research Institute*, Washington D.C.
- 1999b, *Poverty-Environment Interactions in Agriculture: Key Factors and Policy Implications*, United Nations Development Programme and European Commission.
- Sosmena, G 1996, 'Local Government Administration: Challenges and Reforms', in C Carlos, P Tangco, A Tadiar, G Sosmena, M Guillermo & P Omar (eds), *A Reader on Local Political Institute*, Local Government Development Foundation (LOGODEF) & Konrad Adenauer Stiftung (KAS), Manila, Philippines, pp. 68-86.
- Uvin, P & Miller, D 1994, *Scaling up: thinking through the issues*, <http://www.globalpolicy.org>, viewed 10/06/2003.
- Uvin, P 1995, 'Fighting Hunger at the Grassroots: Paths to Scaling up', *World Development*, vol. 23, no. 6, pp. 927-39.

